

PNC	ELC	Brand	Model	Market
910287847	00	Electrolux	Z8273	ZZ

Floorcare

Publication-No.

599709117

2009/09/11

HUV

Floor vac. cleaners

May show more parts than really exist.

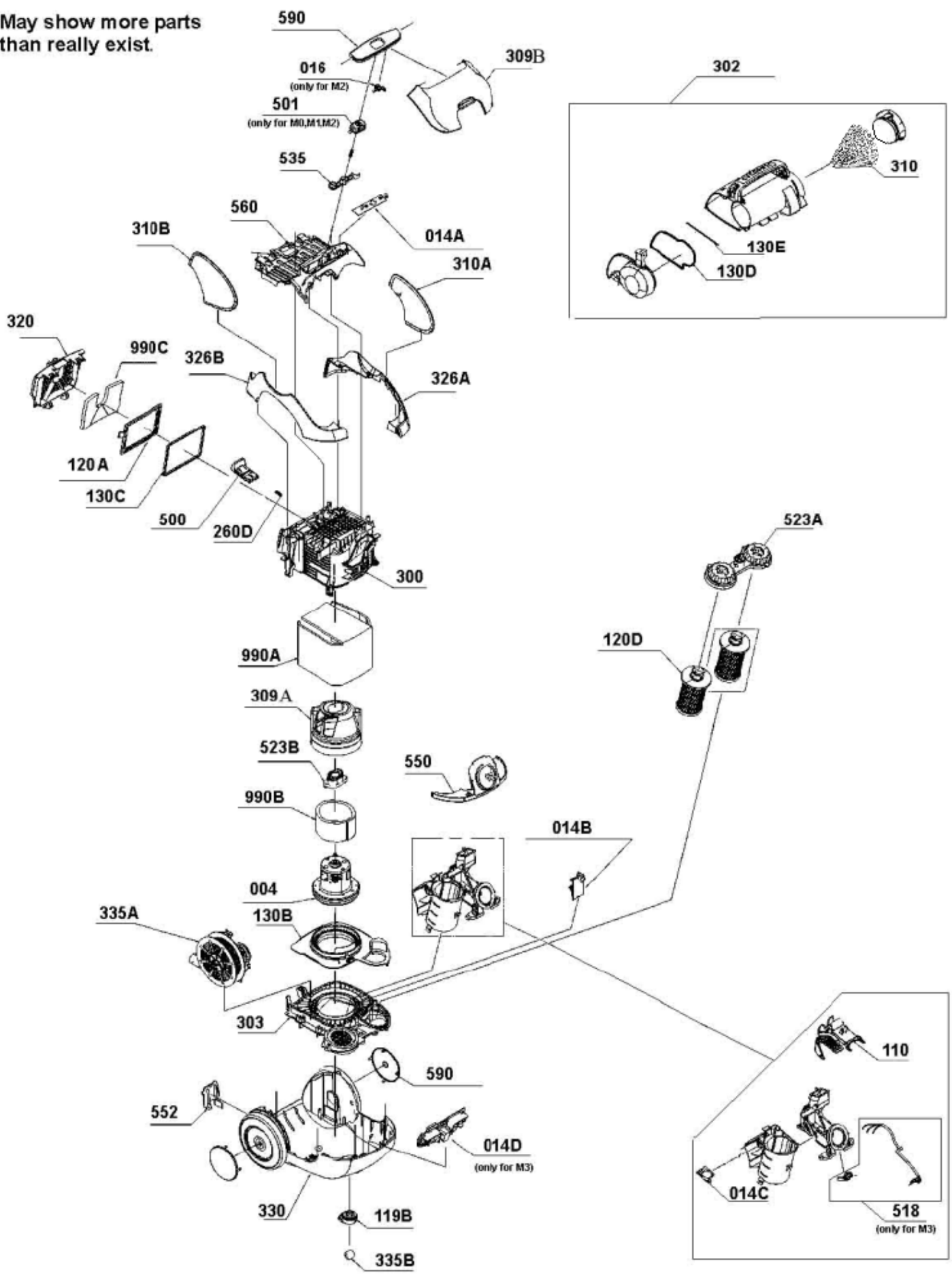

PCALM3000

Matrix	PNC	ELC	ProdDate	Model
A	910287847	00	20080521	Z8273

Pos	Part No.	Matrix	Description
004	2192737126	A	Motor, PY32
014A	1180102533	A	Electronic board, display
014B	1130851700	A	Electronic board, modA
014C	1180133512	A	Electronic board, switch, ROHS
110	2193378011	A	Assembly, blade
119B	1096042047	A	Holder, Wheel, front
120A	2193411010	A	Filter, HEPA
120D	1180048017	A	Filter, complete
130B	2193556012	A	Suspension ring
130C	2192645022	A	Gasket, grill, filter
260D	1130519018	A	Spring
300	1180001016	A	Hood, motor
302	2193599046	A	Dust container, complete
303	1180002048	A	Holder, motor
309A	2193555014	A	Motor cover, Housing
309A	2193555022	A	Motor cover, housing
309B	1180009399	A	Cover, front
310	2194055394	A	Cone, Kit, pistachio green
310A	1180039065	A	Cover, side, left
310B	1180040063	A	Cover, side, right
320	1180006015	A	Grill, filter
326A	2193552011	A	Cover, Wheel, left
326B	2193553019	A	Cover, Wheel, right
330	1180000059	A	Lower part, with wheels
335A	2193131121	A	Cord winder, complete
335B	6680981633	A	Wheel, front
500	1180049031	A	Knob, dust container
501	2193548019	A	Pedal, switch
523A	1180013060	A	Cassette, filter
523B	2193554017	A	Bracket, motor
535	2193549017	A	Reflector, switch
550	1180051011	A	Connector, Hose
552	1180084012	A	Housing, plug
560	1180007021	A	Top cover
590A	1130614033	A	Cover, Wheel
590B	2193602014	A	Cover, display
990A	1180012013	A	Absorber, motor, outer
990B	1130292012	A	Absorber, inner, motor housing
990C	1180071019	A	Absorber, filter, outlet

May show more parts
than really exist.

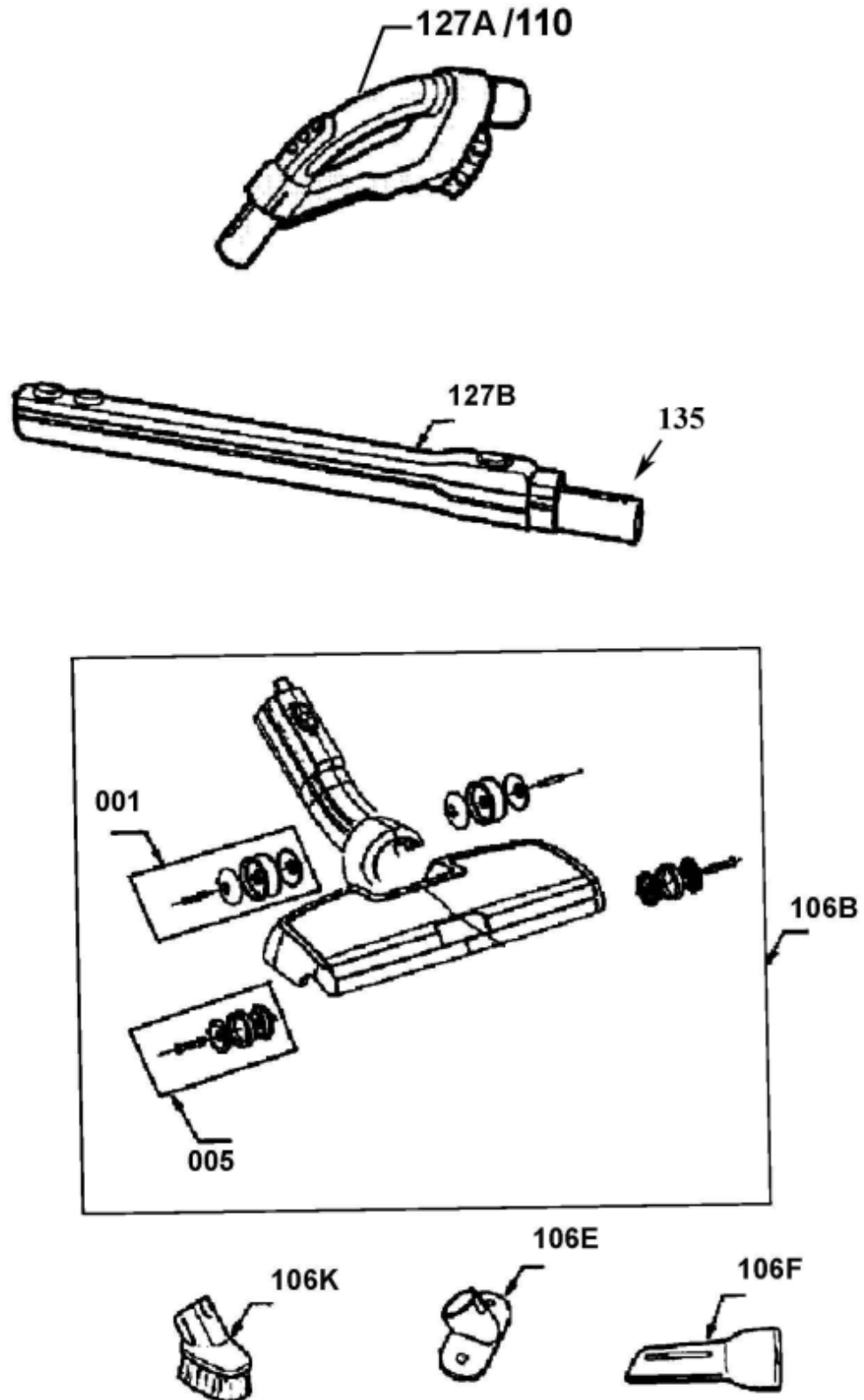

Matrix	PNC	ELC	ProdDate	Model
A	910287847	00	20080521	Z8273

Pos	Part No.	Matrix	Description
001	1131570010	A	Wheel, rear, complete
005	1131600015	A	Wheel, front, complete
106B	1131401653	A	Floor, nozzle, SUMOPassive facelift
106E	1131408526	A	Upholstery nozzle
106F	1131407015	A	Crevice nozzle
106K	1131406017	A	Nozzle, dusting brush
110	1131405621	A	Hose, with, bentend
127B	1131403634	A	Tube, telescope, sumo passive
135	1131439026	A	Sealing ring, TUBE SUMO
999	2192381073	A	Nozzle, TURBODEX WHI/SIL Not shown

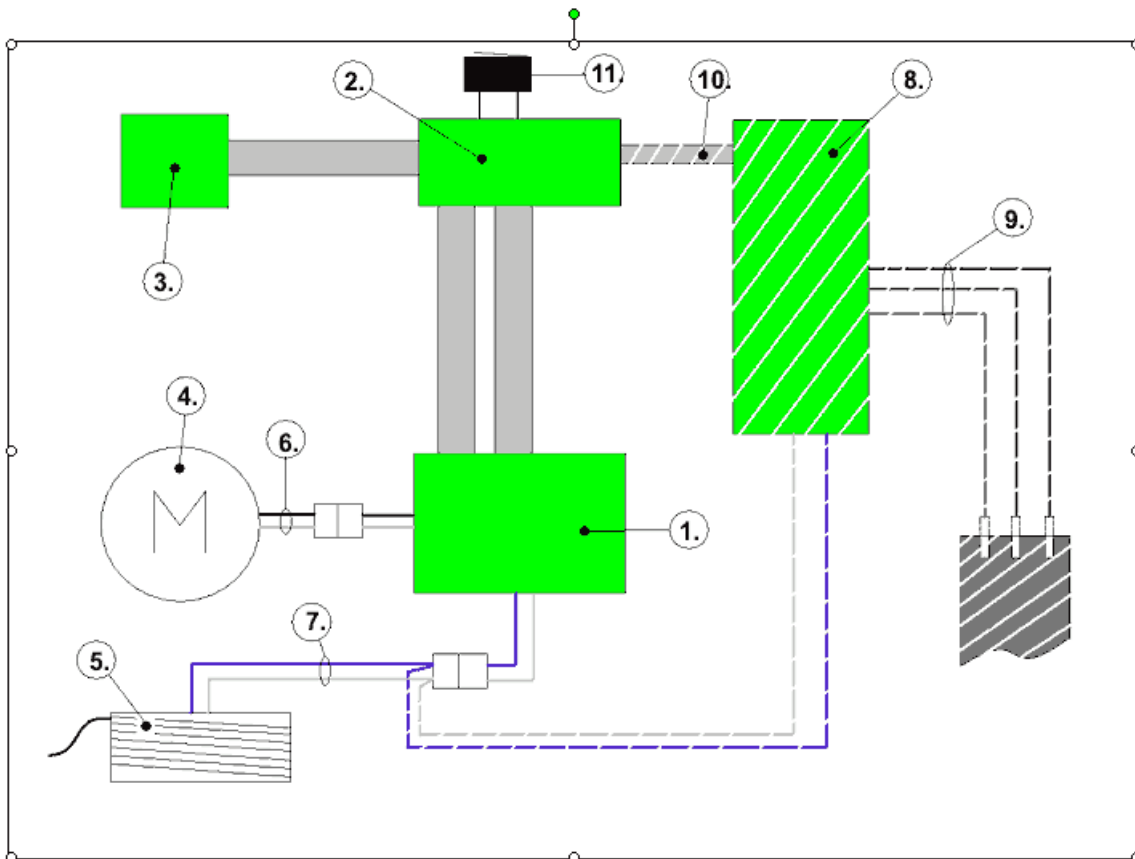

Overview electrical system for Calisto

Schematic no.	Electrolux part no.	Description
1a	113 08 51	Module A processorboard
1b	118 01 10	Module A processorboard UL
2a	118 01 33	Satelite switchboard without sumo Callisto
2b	118 01 03	Satelite switchboard with sumo Callisto
2c	118 01 55	Satelite switchboard with sumo Callisto, UL
3a	118 01 02	Satelite display board mid end version Calisto
3b	118 01 07	Satelite display board low end version Calisto
3c	118 01 08	Satelite display board high end version Calisto
3d	118 01 59	Satelite Display board Callisto, High end UL-version
4	Motor	Separately described
5	Cord winder	Separately described
6	118 01 25	Cable Module A board - motor
7a	118 01 26	Cable Module A board - cord winder
7b	118 01 27	Cable Module A board - cord winder - Sumo power supply
7c	118 01 62	Cable Module A board - cord winder - Sumo power supply US-version
8a	113 11 82	Sumo power supply
8b	118 01 15	Sumo power supply UL
9	118 01 28	Cable Sumo power supply - hose Calisto CE
10	118 01 32	Communication cable Module A boards - Sumo power supply
11	118 01 60	Switch, Easy Clean (included on switchboard)
12	118 01 67	Cable Sumo power supply - hose Calisto UL

Calisto level:	Low M0	Level 1 M1	Level 2 M2	High M3	US
Parts incl.:	1a	1a	1a	1a	1b
	2a	2a	2a	2b	2c
	3b	3b	3a	3c	3d
	4	4	4	4	4
	5	5	5	5	5
	6	6	6	6	6
	7a	7a	7a	7b	7c
				8a	8b
				9	12
				10	10

TECHNICAL DATA

Product

Brand	Electrolux
Model denomination	Z8273
PNC	910 287 847

Technical Specifications

Volt, V	240
Frequency, Hz	50
Max wattage, W	2000
Nominal wattage, W	1800
Cord length, external m	10
Action radius, m	13
Dimension, cleaner only (WxDxH), cm	32,9x40,9x36,4
Weight, cleaner only, kg	7,3
Dustbag size, l	0

Performance

Max vacuum (cleaner complete), kPa	27
Max airflow (cleaner complete), l/s	32
Noise level (cleaner complete), dB(A)	82
Filtration lev,mg/m ³	0,0012
Suction wattage, W	280
Filtration layers, n° of	2